

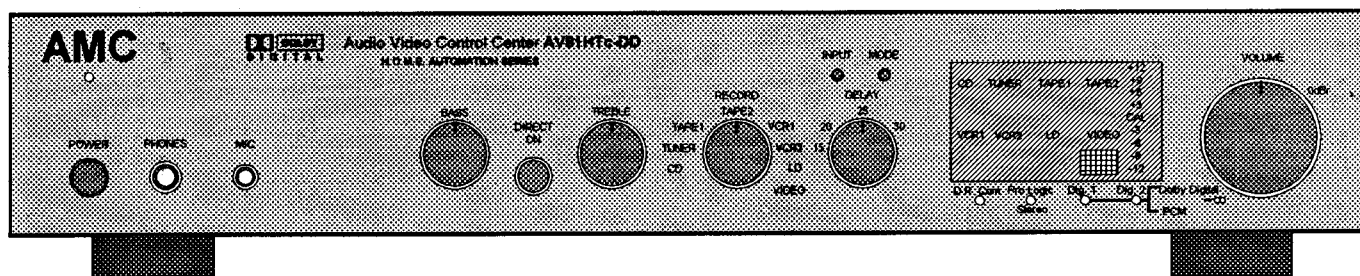

# AMC AV81HTc-DD

## AUDIO VIDEO CONTROL CENTER

\* "Dolby", "Pro Logic" and the double-D symbol are trademarks of Dolby Laboratories.



### INSTRUCTIONS FOR INSTALLATION AND OPERATION



**CAUTION:** TO REDUCE THE RISK OF ELECTRIC SHOCK, DO NOT REMOVE COVER (OR BACK). NO USER-SERVICEABLE PARTS INSIDE. REFER SERVICING TO QUALIFIED SERVICE PERSONNEL.



**ATTENTION:** AFIN DE VITER UN CHOC ELECTRIQUE ET LES CONSEQUENCES GRAVES QUI POURRAIENT EN RESULTER, TENTEZ PAS D'OUVRIR L'APPAREIL ET DE TOUCHER AUX COMPOSANTS INTERNES SANS LA PRESENCE D'UNE PERSONNE QUALIFIEE.



**PRECAUCION:** PARA REDUCIR EL RIESGO DE SACUDIDAS ELECTRICAS, NO DEBERA QUITARSE LA TAPA (NI PARTE POSTERIOR). CONSULTARSE AL PERSONAL CAPACITADO PARA LAS REPARACIONES INTERNAS.

**WARNING:** TO PREVENT FIRE OR ELECTRIC SHOCK, DO NOT EXPOSE THIS APPLIANCE TO RAIN OR MOISTURE.

**ADVERTENCIA:** PARA EVITAR EL RIESGO DE INCENDIO O SACUDIDA ELECTRICA, NO DEBERA EXPONERSE ESTE APARATO A LA LLUVIA O HUMEDAD.

**CAUTION:** TO PREVENT ELECTRIC SHOCK DO NOT USE THIS (POLARISED) PLUG WITH AN EXTENSION CORD, RECEPTACLE OR OTHER OUTLET UNLESS THE BLADES CAN BE FULLY INSERTED TO PREVENT BLADE EXPOSURE.

**ATTENTION:** POUR PREVENIR LES CHOCS ELECTRIQUES NE PAS UTILISER CETTE FICHE POLARISEE AVEC UN PROLONGATEUR. UNE PRISE DE COURANT OU UNE AUTRE SORTIE DE COURANT, SAUF SILES LAMES PEUVENT ETRE INSEREES A FOND SANS EN LAISSER AUCUNE PARTIE FOND SANS EN LAISSER AUCUNE PARTIE A DECOUVERT.

**PRECAUCION:** PARA EVITAR SACUDIDAS ELECTRICAS, NO DEBERA UTILIZARSE ESTA CLAVIJA POLARIZADA CON UN CORDON DE PROLONGACION, RECEPTACULO U OTRO TIPO DE SALIDA A MENOS QUE SE HAYAN INSERTASO COMPLETAMENTE LAS LENGÜETAS PARA EVITAR SU EXPOSICION.

**NOTE:** Some AMC products are equipped with dual or multi-voltage transformers (which is indicated on the back panel). If you wish to change the voltage, please bring your unit to an authorised AMC service technician for internal conversion.

**ATTENTION:** Quelques pièces AMC sont munies de transformateurs à double ou à multi-voltage (indiqué au panneau arrière). Si vous voulez changer le voltage, veuillez apporter votre appareil au fournisseur de AMC pour le transformer.

**ZUR BEACHTUNG:** Einige AMC Geräte sind mit Umschaltern für unterschiedliche Netzspannungen ausgerüstet (Ein Vermerk auf der Rückseite weist darauf hin). Die Anpassung, wenn notwendig, muß von einem qualifizieren Techniker in einer AMC Servicestation vorgenommen werden.

**NOTA:** Ciertos componentes de AMC están dotados de transformadores de doble tensión o de varias tensiones (lo que se indica en el panel posterior). Si se desea cambiar la tensión, sírvanse llevar el aparato a un técnico autorizado por AMC para su conversión interna.

**NOTE to CATV systems installer:** This reminder is provided to call the CATV system installer's attention to Article 820-22 of the NEC that provides guidelines for proper grounding and, in particular, specifies that the cable ground shall be connected to the grounding system of the building, as close to the point of cable entry as practical.

**NOTA PARA EL INSTALADOR DE ANTENAS DE TELEVISION COLECTIVAS:** La presente advertencia se provee para llamar la atención del instalador al Artículo 820-22 de NEC (Código Eléctrico Nacional) donde se facilitan las directrices para la pertinente puesta a tierra y que especifica en particular que el conductor a tierra del cable debe conectarse al sistema de conexión a tierra del edificio, lo más proximo posible al punto de entrada del cable.



The lightning flash with arrowhead, within an equilateral triangle, is intended to alert the user of the presence of uninsulated "dangerous voltage" within the product's enclosure; that may be of sufficient magnitude to constitute a risk of electric shock to persons.



The exclamation point within an equilateral triangle is intended to alert the user of the presence of important operating and maintenance (servicing) instructions in the literature accompanying the appliance.

# APPLICATIONS AND FEATURE LIST

## Features of the AMC model AV81HTc-DD

- \*The AMC model AV81HTc-DD was designed to meet professional quality standards for Dolby Pro-Logic, Dolby Digital decoding and video switching.
- \*Dolby Pro-Logic and Dolby Digital decoding are accomplished by the Zoran ZR38500 Digital Signal Processor. This device is acclaimed worldwide as having the finest sonic quality of any currently available device for decoding Dolby Pro-Logic and Dolby Digital motion picture sound tracks.
- \*With the microphone supplied, a simple calibration procedure can be made that sets the balance of all six channels to an accuracy of less than +/-1dB.
- \*Two Digital Inputs, eight Stereo Audio Inputs and four Composite Video Inputs.
- \*Six Audio Outputs and one Video Output.
- \*Six Output Level pre-set controls precisely set the balance of each of the six output channels.
- \*Switchable sub-woofer crossover filter.
- \*Center channel mode control that provides Normal, Phantom and Wide Band center channel operation.
- \*Center channel Time Alignment control that provides 0,1,2,3,4 and 5 ms delay of the center channel signal relative to Left and Right Channels.
- \*Operating modes include:  
Stereo, Dolby Pro-Logic, PCM, Dolby Digital and Dynamic Range Compression.
- \*Remote Operation of Volume, Source Selection, Modes, Noise Sequence and Power ON/OFF.
- \*Control of surround channel delays of 15,20,25 and 30 ms.
- \*Built-in calibration meter.

# REAR PANEL CONNECTIONS/FRONT PANEL CONTROLS

## REAR PANEL

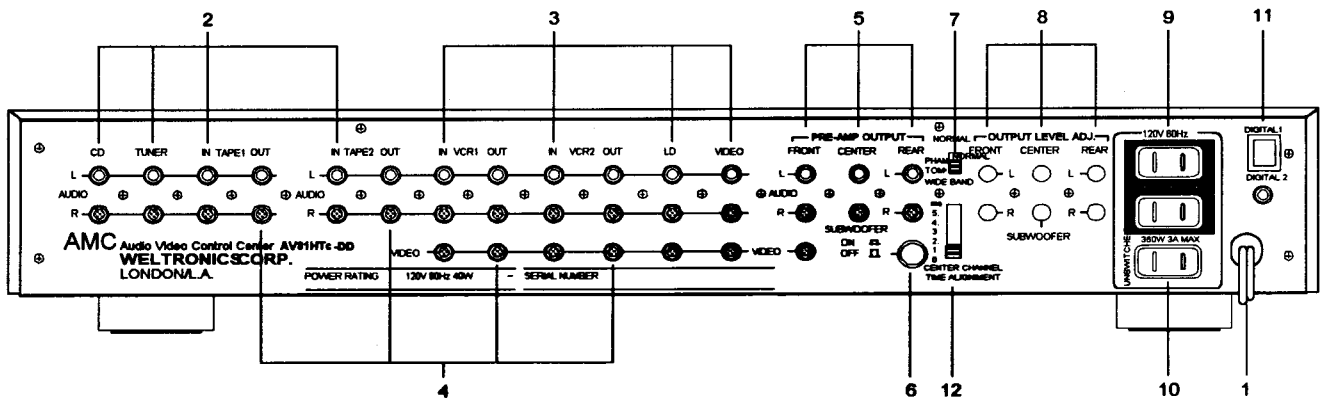

1. AC LINE CORD
2. AUDIO INPUTS: CD, TUNER, TAPE1, TAPE2
3. AUDIO/VIDEO INPUTS:  
VCR1, VCR2, LD, VIDEO
4. AUDIO AND VIDEO RECORDING OUTPUTS:  
TAPE1, TAPE2, VCR1, VCR2
5. PRE-AMP OUTPUTS: FRONT L&R,  
CENTER, REAR L&R, SUBWOOFER, VIDEO
6. SUBWOOFER ON/ OFF SWITCH

7. NORMAL/PHANTOM/WIDE BAND SWITCH
8. OUTPUT LEVEL ADJ: FRONT L&R,  
CENTER, REAR L&R, SUBWOOFER
9. SWITCHED CONVENIENCE AC OUTLETS  
(ONE OUTLET FOR EUROPEAN VERSION)
10. UNSWITCHED CONVENIENCE AC OUTLET
11. DIGITAL INPUTS : DIGITAL 1, DIGITAL 2
12. CENTER CHANNEL TIME ALIGNMENT:  
0, 1, 2, 3, 4, 5 ms

## FRONT PANEL

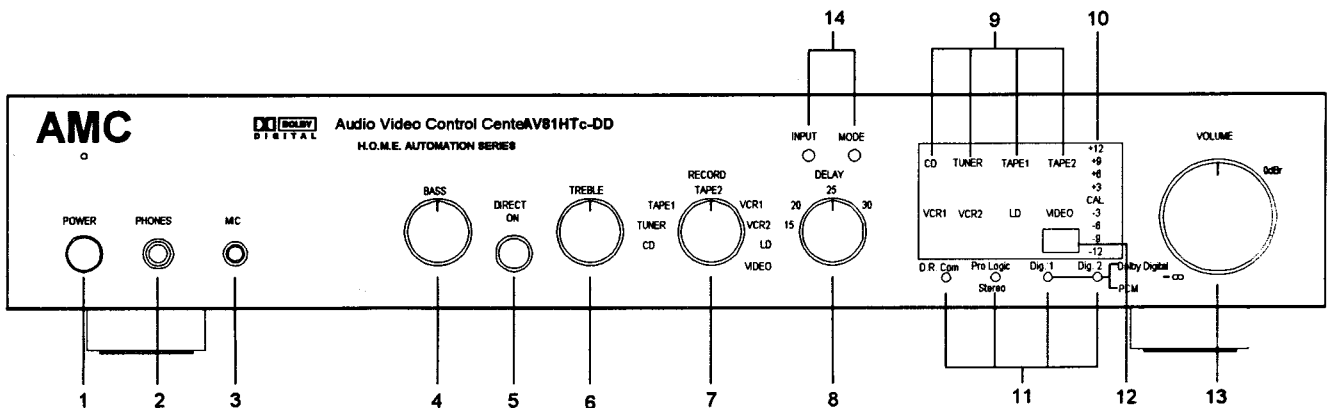

1. POWER SWITCH
2. HEADPHONE SOCKET
3. MICROPHONE INPUT
4. BASS CONTROL
5. DIRECT ON
6. TREBLE CONTROL
7. RECORD SELECTOR SWITCH

8. SURROUND CHANNEL DELAY SWITCH
9. INPUT INDICATOR LED'S
10. CALIBRATION METER LED'S
11. MODE INDICATORS
12. INFRARED RECEIVER
13. VOLUME CONTROL
14. INPUT & MODE SELECTORS

# REAR PANEL CONNECTIONS

## 1. AC LINE CORD

Plug the AC line cord into a nearby wall outlet that provides the correct AC power line voltage, or into an un-switched convenience outlet on any AMC product.

## 2. AUDIO INPUTS: CD, TUNER, TAPE1, TAPE2

These inputs are for connection to audio signal sources via RCA jacks.

## 3. AUDIO / VIDEO INPUTS: VCR1, VCR2, LD, VIDEO

These inputs are for connection to audio/video products via RCA jacks.

## 4. RECORDING OUTPUTS: TAPE1, TAPE2, VCR1, VCR2

These outputs are for recording and are controlled by the RECORD selector switch on the front panel.

## 5. PRE-AMP OUTPUTS: FRONT L&R, CENTER, REAR L&R, SUBWOOFER

These outputs are for connections to the inputs of the power amplifiers. Connections are made via RCA jacks.

## 6. SUBWOOFER ON/OFF SWITCH

If a subwoofer is being used, the subwoofer switch should be pressed in. In this position, the built-in 80Hz cross-over is activated. If a subwoofer is not used, the switch must remain in the out position.

## 7. NORMAL/PHANTOM/WIDE BAND SWITCH

This switch provides 3 modes of operation for the center channel. These modes are described as follows:

**"Normal"** mode re-directs very low frequencies that would normally appear at the output of the center channel, to the front left and right speakers. This allows a small/compact speaker to be used for the center channel.

**"Phantom"** mode assumes that no loudspeaker is used for the center channel. In this mode, all signals that would normally appear at the output of the center channel are re-directed to the front left and right speakers.

**"Wide Band"** mode can be used when the center channel speaker can handle the full frequency range and is not limited at low frequencies.

## 8. OUTPUT LEVEL ADJ: FRONT L&R CENTER, REAR L&R, SUBWOOFER

The output level adj. controls are used in conjunction with the built-in test noise generator and calibration meter to balance/calibrate the entire audio section of your home theater system. The calibration procedure is very simple and is described as follows:

a) Pre-set all output level adj. controls to their mid position.

b) Plug the microphone into the front panel "MIC" socket and place the microphone where you would be normally seated.

c) Press the "DOLBY PRO-LOGIC" button on the RC-001 remote control and select any analog input, then press the "TEST" button on the remote control to start the TEST noise generator. Noise will appear at the front left speaker.

d) Adjust the master volume on the front panel so that the orange (Cal.) LED lights on the calibration meter. This sets the calibration level for the left channel. The master volume control should not be moved when calibrating the remaining channels.

e) To calibrate the center channel, press the "TEST" button on the remote control again. The noise generator will now switch to the center speaker. Then adjust the center channel output level adj. control on the rear panel until the orange (Cal.) LED lights. The center channel is now calibrated.

f) To calibrate the remaining channels, simply repeat the procedure described in e) above and adjust the appropriate output level adj. control.

## 9. SWITCHED CONVENIENCE AC OUTLETS

There are 2 switched convenience AC outlets for 120V versions and only one for 220V/230V/240V versions. These convenience AC outlets are controlled by the power ON/OFF button on the front panel and RC-001 Remote Control.

## 10. UNSWITCHED CONVENIENCE AC OUTLET

There is one un-switched convenience AC outlet for 120V versions and none for 220V/ 230V/ 240V versions.

## **11. DIGITAL INPUTS**

Digital 1 : Fiber Optical Input (S/PDIF FORMAT)

Digital 2 : Coaxial Input (S/PDIF FORMAT)

## **12. CENTER CHANNEL TIME ALIGNMENT**

This switch provides a selectable Center channel signal delay from 0mS to 5mS in 1mS increments, relative to the Left and Right front channels. The purpose of this signal delay is to provide a Center channel signal that is coincident in time with the signals from the Left and Right channels at the listening position. To set this switch, first position the Left and Right channel speakers equally from the listening position and note the distance. Then measure the distance between the Center channel speaker and the listening position. If the Center channel speaker distance is less than that for the left/Right speakers, time delay must be added to the Center channel in order that all three acoustic signals arrive at the listening position at the same time. For example, if the Center channel speaker is positioned 2 feet shorter from the listening position compared to the Left/Right speakers, the Center channel delay switch should be set for a delay of 2mS (1mS for every foot). No time alignment is possible for Center channel speaker that are positioned further away from the listening position than the Left/Right speakers.

# FRONT PANEL CONTROLS

## 1. POWER SWITCH

Press to turn on AV81HTc-DD. Press again to turn off. When AV81HTc-DD is turned on, the small indicator above the switch will glow green.

## 2. PHONES

The headphone socket will accept any headphones fitted with a standard quarter inch (6.35mm) stereo jack plug. When a headphones plug is inserted into the PHONES socket the AUDIO OUTPUTS on the REAR PANEL are automatically shut off. If you want to listen to speakers, you must remove headphone plug from the socket.

## 3. MIC

During setting up the Home Theater system, plug microphone included with the unit into this socket.

## 4. BASS

The Bass control adjusts the relative level of the low frequencies in the sound. The electrical response of the amplifier is flattest when the control is set in the detent or 12 o'clock position. Rotation of the knob to the right (clockwise) increases the level of low-frequency sounds, and rotation counter-clock-wise decreases their level. Adjust the Bass control to achieve the tonal balance that sounds most natural to you.

## 5. DIRECT ON

When this button is pressed the LED above the switch will light up and the Bass and Treble circuits are completely bypassed, restoring precisely flat frequency response. When this button is pressed again, the LED above the switch will be turned off, the tone controls operate normally. By adjusting the tone controls and then switching them in and out of the signal path, you can evaluate their effect on the sound.

## 6. TREBLE

The Treble control adjusts the relative level of the high frequencies in the sound. The response of the amplifier is flattest when the control is set in the detent or 12 o'clock position. Rotation of the Treble control to the right (clockwise) increases the level of high-frequency sounds, and rotation counter-clockwise decreases their level. Adjust Treble control to achieve the tonal balance that sounds most natural to you.

## 7. RECORD

This switch selects the input signal for recording. (to RECORD OUTPUTS on REAR PANEL)

## 8. SURROUND CHANNEL DELAY

This switch sets the delay for the Rear channels from 15mS to 30mS in 5mS increments relative to the Left and Right front channels. The delay is required in order to create a precedence effect in the Dolby Pro Logic mode. The switch is simply adjusted to give the best Rear channel effects. In Dolby Digital mode, this delay is automatically reduced by 15mS, because in this mode, Dolby Digital delivers discrete to all channels.

## 9. INPUT SELECTOR LED's

There are 8 LED's arranged in 2 rows, in the front panel display These LED's indicate the selected input (CD, TUNER, TAPE1 TAPE2, VCR1, VCR2, LD. VIDEO ).

## 10. LEVEL METER LED's

Indicate relative levels of each channel.

## 11. MODE LED's

Indicate modes of the system:

D.R. Com( Dynamic Range Compression ), Stereo (Green ), Pro Logic (Red), PCM (Green), Dolby Digital (Red).

## 12. INFRARED RECEIVER

Hidden behind the front panel window is a infrared receiver to receive infra rays from the remote control (RC-001).

## 13. VOLUME CONTROL

The Volume Control adjusts the overall loudness level of the sound. It has no effect on the level of the signals fed to the TAPE OUT jacks.

## 14. INPUT & MODE SELECTORS

Specific input and mode functions can be accessed through the front panel INPUT and MODE buttons. The scrolling action of these buttons enable easy selection of the desire input or mode function.

# REMOTE CONTROL(RC-001)

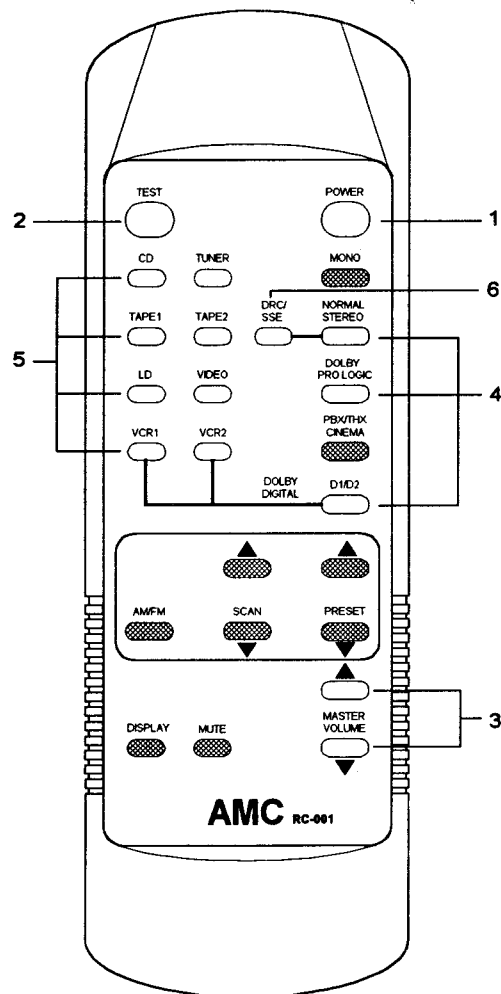

## 1. POWER

Pressing the green "POWER" button switches the AV81HTc-DD power on. Pressing the button again will turn the AV81HTc-DD off.

## 2. TEST

The AV81HTc-DD is provided with a built-in test noise generator to calibrate each channel of your home theater system when first installed. Access to the noise generator set-up mode is made available only when the AV81HTc-DD is in the Dolby Pro-Logic mode and switched to any analog input. After selecting this mode, pressing the "TEST" button for the first time starts the noise generator and connects it to the front left channel. The noise generator can be switched to each channels in the sequence: front left (start), center, front right, rear right, rear left and sub-woofer by pressing the TEST button repeatedly. Normal operation is resumed at the end of this sequence. See page 4 item 8 for detailed instructions on adjusting the output levels for each channel.

## 3. MASTER VOLUME

- ▲ VOLUME UP
- ▼ VOLUME DOWN

## 4. MODES

These buttons select any one of the four modes: STEREO, DOLBY PRO LOGIC and D1/D2 Dolby Digital or PCM.

## 5. INPUT SELECTOR

These buttons select any one of the eight sources that are connected to the inputs of the AV81HTc-DD (CD, TUNER, TAPE1, TAPE2, VCR1, VCR2, LD & VIDEO )

## 6. DYNAMIC RANGE COMPRESSION

Pressing the DRC button activates the Dynamic Range Compression circuit, which limits the exceptionally wide (20 bit) dynamic range of Dolby Digital signals. This function is especially useful when listening at low volume settings, where the ultra fine details of dialog and musical signals might otherwise be lost during quiet passages. This function can only be activated when Dolby Digital signals are being reproduced.

## 7. OTHER BUTTONS WITH

Buttons on the RC-001 remote control that are not mentioned above, are for use on other AMC high end Audio/Video products.

# SPECIFICATIONS

## AUDIO INPUTS (CD, TUNER, TAPE1, TAPE2, VCR1, VCR2, LD & VIDEO) AND OUTPUTS

### STEREO MODE

Input impedance.....	R=47K ohm, C=100pF
THD 20Hz-20KHz and SMPTE IMD.....	<0.01% at 3Vrms
Inputs sensitivity for 1V output.....	150mV
Input overload.....	3.5Vrms
Signal to noise ratio (Gain=1).....	95dB "A" wtd ref. 1V
Frequency response.....	20Hz-20KHz +/-0.5dB
Output impedance.....	75 OHM
Maximum output level.....	12 Vrms
Subwoofer cross-over frequency.....	80Hz
Tone control 100Hz.....	9+/-0.5dB
10KHz.....	8.5+/-0.5dB

## VIDEO INPUTS (VCR1, VCR2, LD & VIDEO) and OUTPUTS

Input impedance.....	75 OHM
Input level for peak white.....	1V peak
Output impedance.....	75 OHM
Gain (From Video Inputs to Output).....	Unity with 75 OHM term
Frequency response.....	DC-6MHz +/-1dB DC-18MHz +/-6dB
Max. input level.....	+/-2V peak

## DOLBY DIGITAL MODE

Output level @ 1KHz/0 dBFS.....	Variable, max. 9V at clipping
THD+N @ 0 dBFS/2V output	Main channels.....0.006% at 1KHz
	Surround channels.....0.006% at 1KHz
	Center channel.....0.006% at 1KHz
	LFE.....0.006% at 30Hz
Channel separation at 1KHz/2V output.....	>80dB
Signal to noise ratio @ -20 dBFS.....	>70dB

## OTHER

Dimensions (WxHxD).....	430x82x300 mm
Net weight.....	5.0Kgs. (11 lbs.)
Power consumption.....	30W

Manufactured under license from Dolby Laboratories. "Dolby", "Pro Logic" and the double-D symbol are trademarks of Dolby Laboratories. Confidential Unpublished Works. © 1992-1997 Dolby Laboratories, Inc. All rights reserved.

Weltronics Corp. reserved the right to improve its products at any time. Therefore, specifications are subject to change without notice.

