

# AMC T7a

## RDS Module Installation Procedures

Revision Date: 2001-04-11

### Before Installation

There are three versions of AMC T7a main PCB manufactured to date. Please locate the part number on the PCB close to the power supply. The following table lists all possible part numbers:

90-1286	Original version
90-1286*A	Revision A
90-1286*B	Revision B

### Installation Procedures

The following installation procedures are designed for T7a with 90-1286\*A or 90-1286\*B part numbers: (Please see next section for information on 90-1286 installation notes)

1. Power down T7a.
2. Unplug T7a from the electrical outlet (to make sure no power is applied to T7a).
3. Place T7a on a service bench or a flat table suitable for installation.
4. By using a Philip screw driver, please take 6 screws off the case. The location of the screws are indicated below:

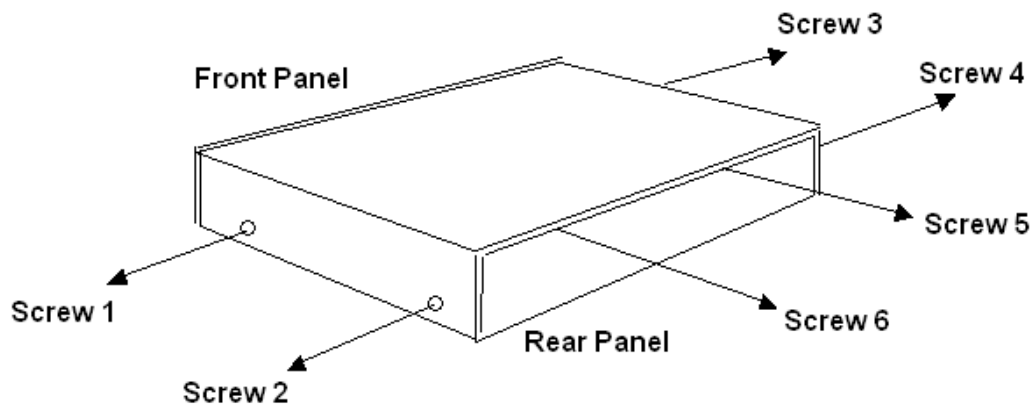

5. Slide off the case away from T7a

6. Unscrew 2 screws off the Power Transform indicated below:

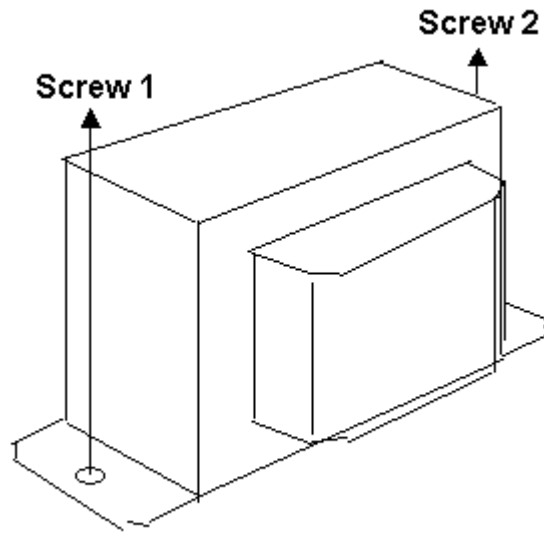

7. Move this Power Transformer module 1 to 2 inches toward rear panel in order to leave a space for RDS module installation.

8. Tear off the "RDS Ready" label or black color label on the back of the RDS display window.

9. Place and fit the RDS module on the RDS display window.

- If the PCB of RDS module is not touching the 5 stand off posts, please add 5 washers between PCB of RDS module and stand off posts. In order to hold the washers on the PCB, please use double side tapes.

- If the PCB of RDS module is touching the 5 stand off posts, please continue.

10. Screw RDS Module into RDS display position using 5 M3x6mm screws included in the RDS Module Kit.

11. Plug the 3P plug of the short ribbon wire (3 wires) from CN102 to the JP102 socket on the Tuner Display module (located side by side with CN102)
12. Plug the 2P plug of the longer shielded wire from CN101 to 2P socket CN7 on Tuner Main PCB Module.

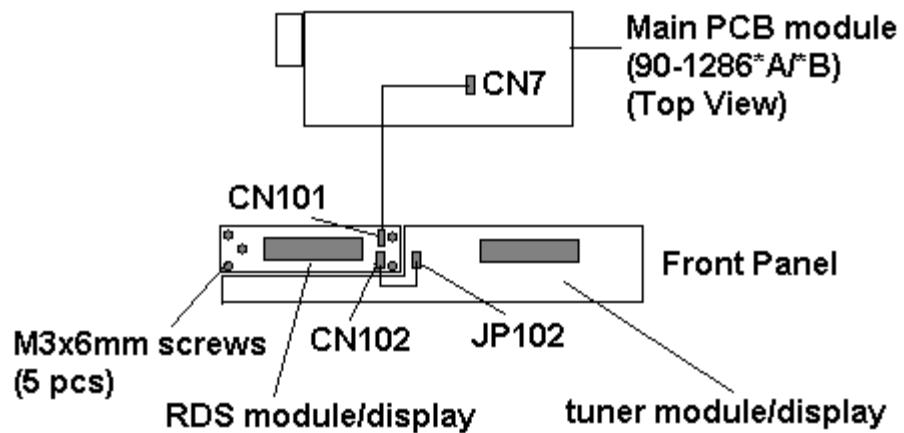

13. Place Power Transformer back to original location. Place two screws back to the original location.
14. Put screw locking glue on 5 screws fixing of the RDS module and 2 screws on the Power Transformer
15. Slide the case back to T7a.
16. Place 6 screws back to its original location on the case.
17. Done

**The Installation Procedure for T7a with 90-1286 Tuner Main PCB part number has the same procedures except for procedure 12. Please replace procedure 12 with the following instruction:**

12. Please cut the 2P plug at the end of the longer shielded wire off and strip the two ends of wires. Solder the white wire to pin 12 of IC1 (LA1266) and the black wire lead to the case of IFT (GND of IFT).

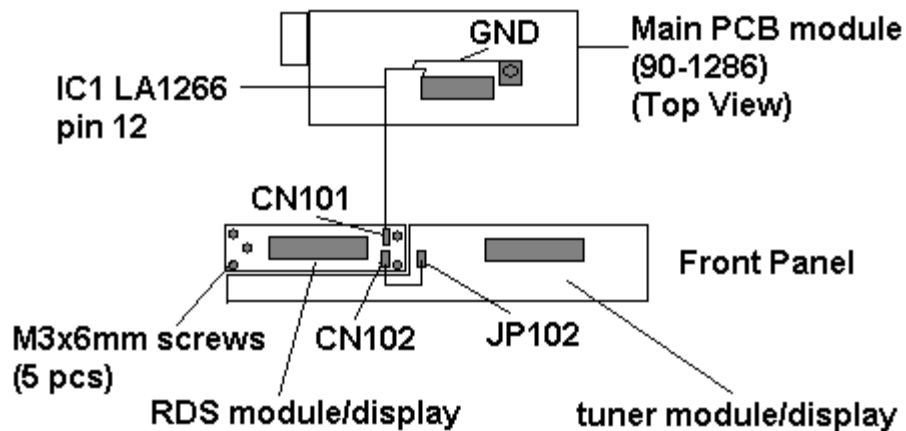

### After Installation

Please test the installation with the following procedures:

1. Select a FM station with RDS. (Please check your local listing for channels supporting RDS transmission)
2. You should be able to enjoy the RDS features if it is working properly.